



## EMBEDDED IN SANDY SOILS WITH CAVITIES

Dr. Mosa J. Al-Mosawe  
Professor, University of Baghdad,  
College of Engineering, Civil Eng.  
Department

Dr. Yousif J. Al-Shakarchi  
Professor, University of  
Baghdad, College of  
Engineering, Civil Eng.  
Department

Saheem M. Al-Taie  
Formerly Graduate Student  
University of Baghdad, College of  
Engineering, Civil Eng.  
Department

### ABSTRACT

A program of laboratory testing is carried out to study the performance of laterally loaded piles embedded in soil, which contains cavities. The testing apparatus is manufactured for carrying out the tests and a simple technique was used to simulate the cavities.

The program of testing consists of five groups: Group One was carried out on pile embedded in soil without cavities. The Second and Third Groups are performed on pile embedded in soil contains single cavity located in front and in touch with pile face for the Second Group and in back and in touch with pile face for the Third one. Group Four is performed on pile with the existence of two cavities located in front and in touch with pile face. Group Five is performed on pile with the existence of three cavities located in front and at a variable distance from pile face. All tests are performed on a free head pile subjected to horizontal load.

The results of this study indicate that the number of cavities and their location have a combined effect on the behavior of laterally loaded pile. The effect of cavities located in front of the pile is marginal at  $X/D > 8$  where  $X$  is the spacing between cavity and pile and  $D$  is the diameter of the pile.

### الخلاصة

لدراسة تصرف الركائز المحملة أفقياً والمدفونة في تربة تحتوي على تكهفات ، فقد تم وضع برنامج فحوص مختبري يتضمن دراسة تصرف نماذج من ركائز صغيرة مدفونة في تربة رملية مفككة صيغت بداخلها فجوات. وقد تم تصنيع جهاز لتنفيذ البرنامج مع استعمال تقنية بسيطة لتمثيل الفجوات. هذا ويحتوي برنامج الفحص خمس مجاميع: المجموعة الأولى: أجريت على ركيزة مدفونة في تربة خالية من الفجوات. المجموعة الثانية: أجريت على ركيزة مدفونة في تربة تحتوي على فجوة واحدة وموقعها أمام الركيزة ومتماسكة مع سطحها. ويتغير بعد الفجوة عن سطح التربة في كل فحص. المجموعة الثالثة: مماثلة للمجموعة الثانية باستثناء موقع الفجوة حيث ان موقعها في هذه المجموعة خلف الركيزة. المجموعة الرابعة: أجريت على ركيزة مدفونة في تربة تحتوي على فجوتين وموقعيهما أمام الركيزة ومتماستين معها، المجموعة الخامسة: أجريت على ركيزة مدفونة في تربة تحتوي على ثلاث فجوات وموقعها هو أمام الركيزة وتبعد مسافات مختلفة عن سطح الركيزة في كل فحص. هذا وان الفحوص أجريت على ركائز حرة في حركة الراس **free head** ومعرضة لقوى أفقية مع تغيير في نسبة اللامركزية. وبينت نتائج الفحوص ان هنالك تأثيراً مشتركاً بين عدد الفجوات وموقعها على أداء الركائز المحملة أفقياً. ويتلاشى تأثير الفجوات على سلوك الركائز عندما تكون على بعد  $X/D$  أكبر من 8 حيث ان  $X$  هو المسافة الأفقية بين سطح الفجوة و سطح الركيزة و  $D$  هو قطر الركيزة.

## **KEY WORDS**

**Cavities, Pile, Lateral load, Sand**

## **INTRODUCTION**

There are many cases in practice where piles pass through different layers of soils that contain cavities located at different depths and locations. In such kind of sites, cavities will affect drastically the pile performance and therefore it is vital to pay attention to this effect with great care.

## **AIM OF THE PRESENT WORK**

The aim of the present work is to study the effect of cavities in loose sandy soil on the performance of laterally loaded piles. The parameters studied are the location, depth and number of cavities. The effect of these parameters on the performance of the pile subjected to horizontal loading is studied and the results are analyzed.

## **FAILURE MECHANISM**

Al-Shakarchi, (1965) performed laboratory tests on laterally loaded pile embedded in cohesionless soil. Under the application of horizontal load on vertical single pile, the process of movement of the particles of soil around the pile that the pattern of motion of soil particles at failure for the upper two third of pile length is upwards in the same side of the pile at which the load is applied and a passive zone is developed. The pattern of motion of particles is downwards at the opposite side of the pile and represents active zone. At the lower one third of the pile length, the direction of soil particles movement is in the opposite directions of the upper two third length of pile, i.e. passive resistance is developed in the opposite side of the pile at which the load is applied.

## **PREVIOUS WORKS**

The available works and studies concerning the problem of piles subjected to horizontal loads are limited to soils without cavities. The only available work related directly to the present problem is the experimental work performed by Ziyazov (1976). Other works which are related indirectly to the present problem are the works performed experimentally about the performance of footing above cavities, Badie and Wang (1984).

## **THE APPARATUS**

The apparatus shown in Fig. (1) consists of: steel container, pile fixing tool, the dial gauge fixing tool and the loading system.

### **Steel Container**

The sand container is made of steel plates with internal dimensions of 640 mm in length, 290 mm in width and 395 mm in height as shown in Fig. (1a).

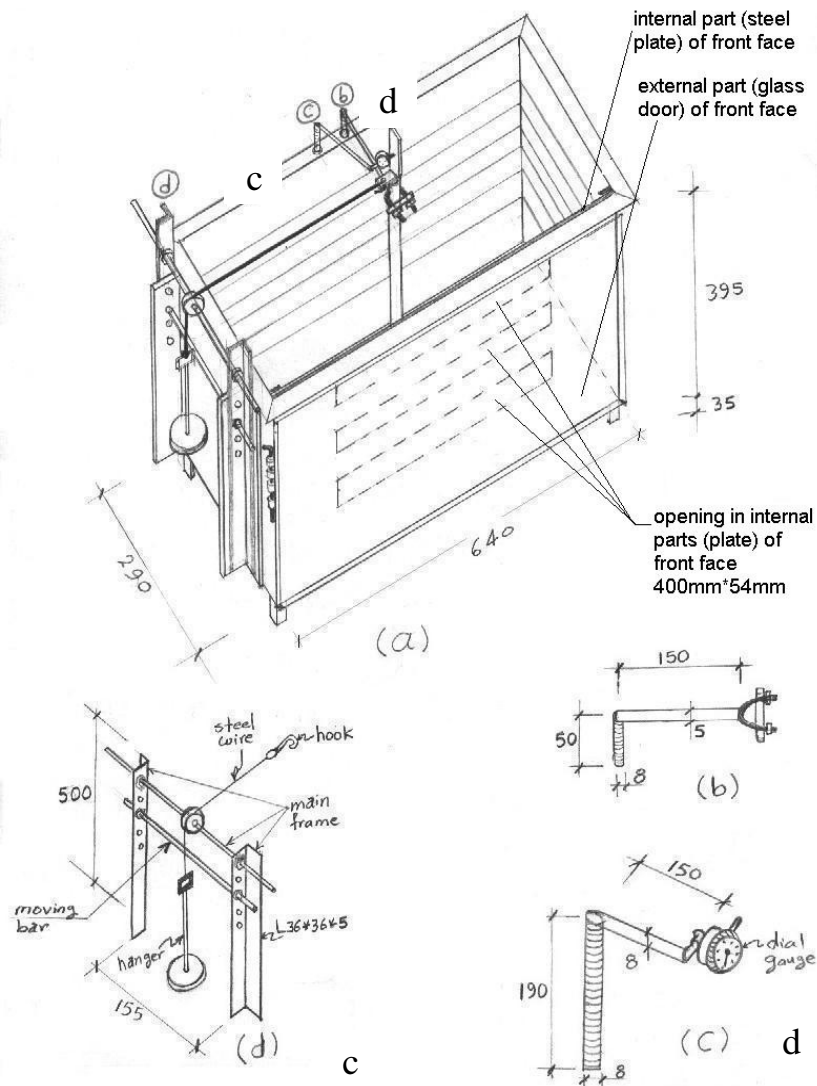

**Fig.(1):** The apparatus: a) The steel container, b) Pile fixing tool, c) Loading system, d) Dial gauge fixing tool

## THE PILE MODEL

The pile model is made of solid steel metal with a circular cross section of 15 mm diameter. The total length of the pile varies between 345mm and 480mm. The yield strength of the pile metal ( $F_y$ ) is 380 MPa, while the modulus of elasticity ( $E_p$ ) is  $2.05 \times 10^5$  MPa. According to the criteria proposed by Broms (1965) the pile used is considered rigid.

## THE SAND Properties

The sand used is Kerbala sand, which is washed with water to remove dust as much as possible. Then the sand is air dried;

The grain size distribution curve is shown in Fig. (2).

The properties of the sand as obtained from laboratory tests are listed below :

Specific gravity	$G_s$	= 2.66
Void ratio	$e_{max}$	= 0.88
	$e_{min}$	= 0.41
Void ratio used	$e$	= 0.74
Relative density	$D_r$	= 30 %
Coefficient of uniformity	$C_u$	= 2.86
Mean grain size	$D_{50}$	= 0.60 mm
Angle of internal friction	$\phi$	= 30 °

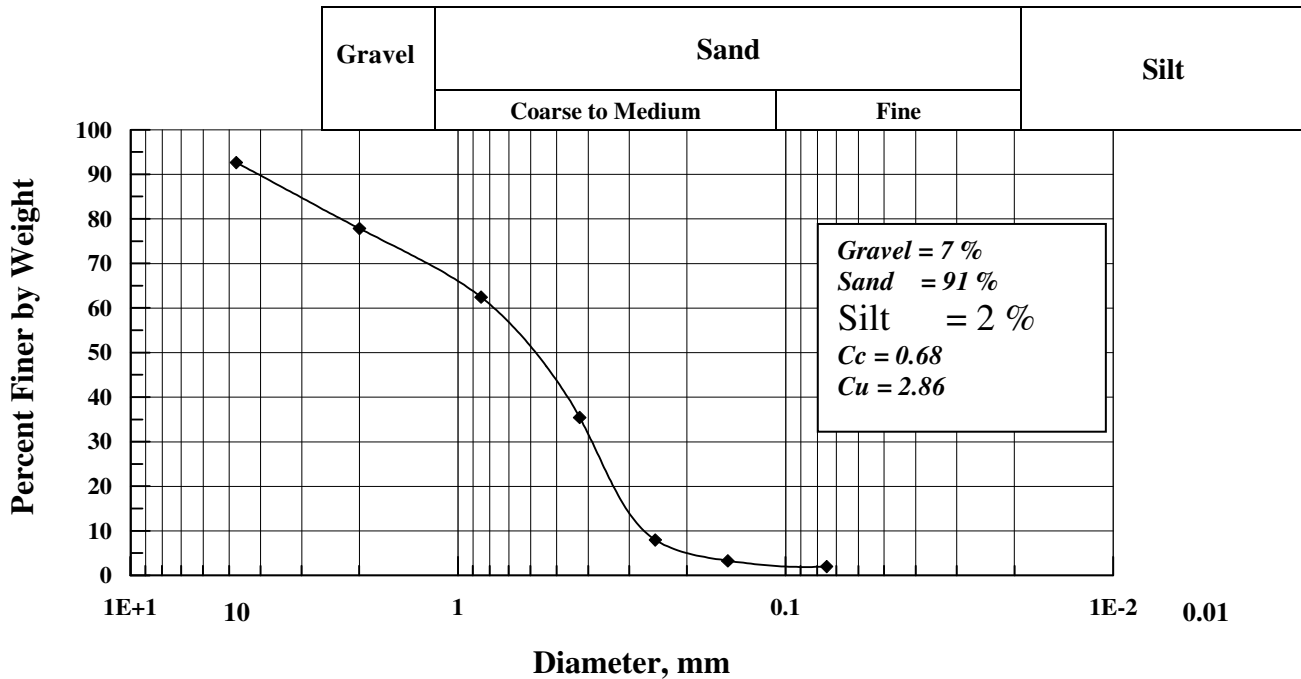

**Fig. (2):** Grain Size Distribution Curve for the Tested Sand (ASTM.) Standard

**The bed of soil**

The bed of soil is prepared in the form of layers of different thicknesses. Water corresponding to the 4 % -moisture content is then added gradually using a water sprinkler and mixed thoroughly with the soil. Care is taken to distribute the water evenly, then the mixture is spread inside the container and compacted with steel tamping hammer, until the required unit weight is achieved.

P.V.C. pipes, 50 mm diameter and 290 mm long, are used to form the cavities. They are placed in the required position during compaction process. Compaction continues until the final bed is achieved. After the completion of the bed of soil, the glass door, as in Fig. (1a), is opened and the P.V.C. pipes are withdrawn out of the container, then the door is closed.

The horizontal load is applied in suitable increments so as to get sufficient number of points for the load – displacement curve. The magnitude of suitable increment is found to be equal to ¼ kg. The last increment is applied when the rate of horizontal displacement does not exceed 0.02 mm per hour.

**TESTING PROGRAM**

The testing program is shown in Table (1). It should be mentioned that the tests are performed on free head piles.

**Table (1): Testing program**

Grou p No.	X mm	h* mm	L= 300 mm				Remarks
			e/L				
			0.15	0.30	0.45	0.60	
<b>I</b>			*	*	*	*	Soil without cavity
<b>II</b>		50	*		*		
		100	*		*		
		150	*		*		
		200	*		*		
		300	*		*		
<b>III</b>		100	*				
		200	*				
		300	*				
<b>IV</b>	100	150	*		*		
	100	200	*		*		
	100	250	*		*		
	150	150	*		*		
	150	200	*		*		
	150	250	*		*		
<b>V</b>	0	200	*	*	*	*	
	20	200	*	*	*	100*	
	40	200	*	*	*	100*	
	60	200	*	*	*	100*	
	80	200	*	*	*	*	

h\* is the distance between the center of the cavity or the group of cavities

**ESULTS AND DISCUSSION**

Many references indicate some of the recognized criteria for defining failure loads of piles under compressive loads, but there is no criterion to define the failure load of laterally loaded piles

except some notes in some references: Mc Multy (1956), Hopkins (1956), Soneja and Garg (1980), Bowles (1988) and Kashat (1990).

### ANALYSIS OF THE RESULTS

To analyze the results of the present work, a load required to produce a horizontal displacement 2 mm is considered as working load.

#### Group I: Piles embedded in soil without cavity.

The length of embedment is constant,  $L=300\text{mm}$  and the eccentricity is variable,  $e=45\text{mm}$ ,  $90\text{mm}$ ,  $135\text{mm}$  and  $180\text{mm}$ .

One can notice from Fig. (3) that the load required to produce a certain horizontal displacement decreases with the increase in eccentricity ratio. The load required to produce 2 mm horizontal displacement is shown in Table (2).

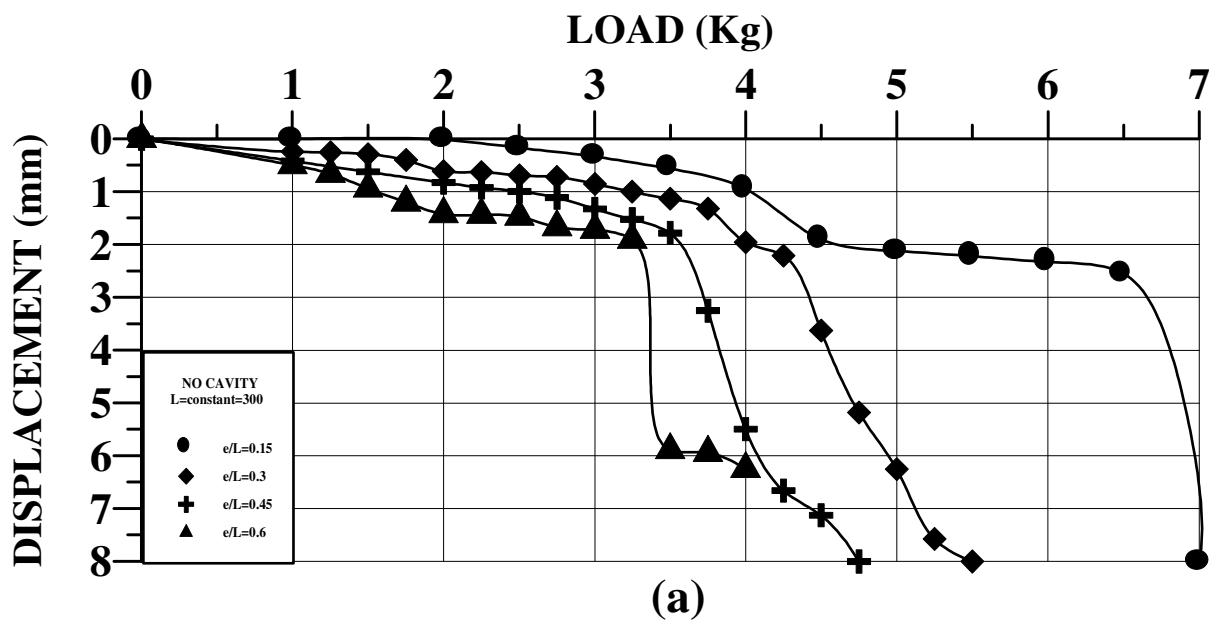

**Fig.(3):** Variation of horizontal load versus horizontal displacement for no cavities group (group I).  $L=300\text{mm}$ ,  $e/L=0.15, 0.30, 0.45$  and  $0.60$ .

Table (2): Working load of piles embedded in soil without cavities in (N).

$e/L$	0.15	0.30	0.45	0.60
P	46	40	36	33

#### Group II: The cavity is in touch and in front face of the pile.

Tests of this group are made as indicated in testing program Table (1), with constant  $L=300\text{mm}$   $e/L=0.15$  and  $0.45$

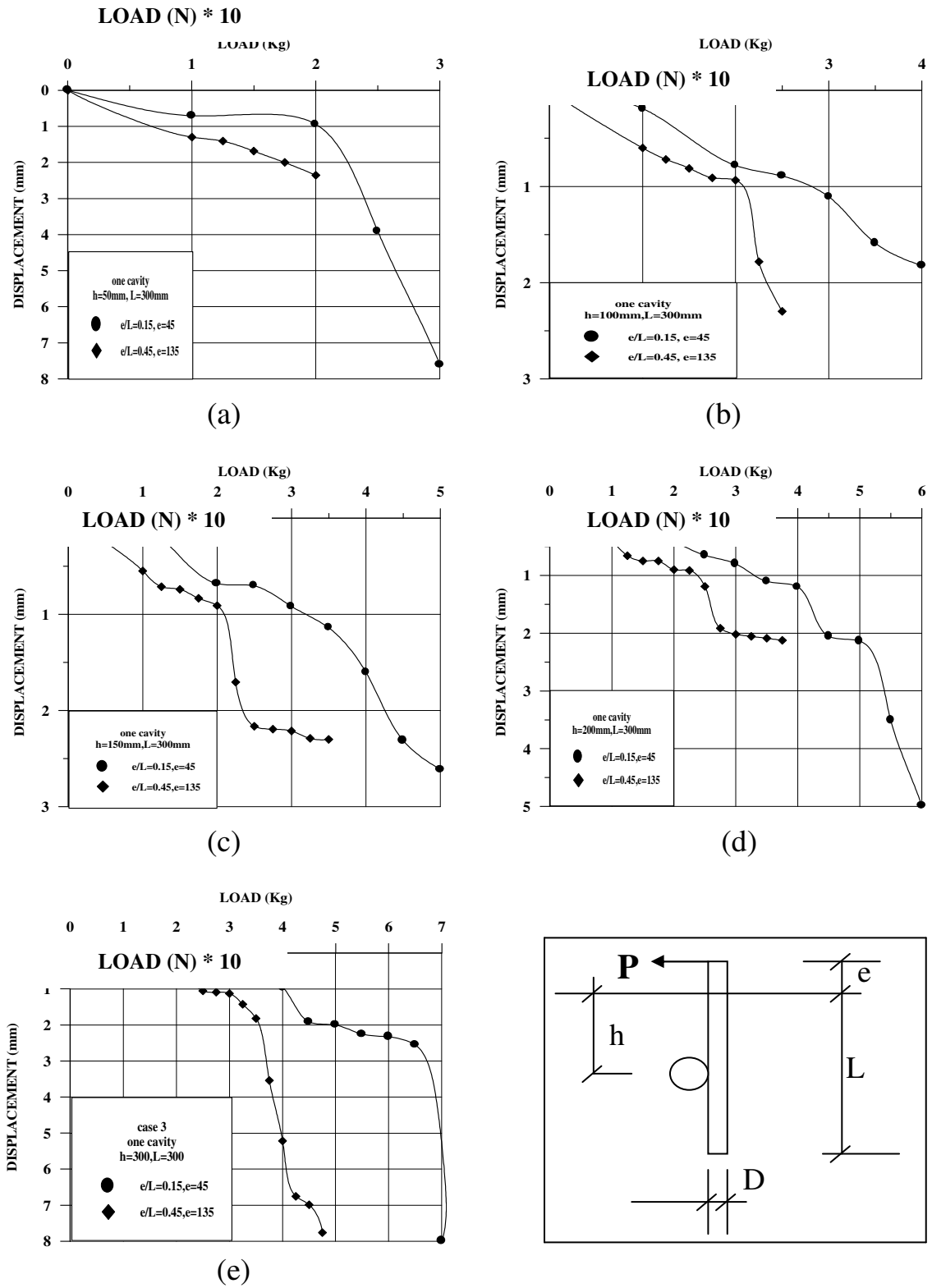

Fig(4): Variation of load versus displacement with varying eccentricity ratio (group II, one cavity, L=300mm)

The load re (a) h=50mm (b) h=100mm (c) h=150mm (d) h=200mm (e) h=300mm

h (mm)	L=300mm	
	e/L	
	0.15	0.45
0*	46	36
50	24	22.5
100	40	23
150	42.5	23.2
200	44.5	30
300	46	36

\*h=0 denotes soil without cavity

Generally, the variation of load versus displacement shown in Fig. (4) indicates that the displacement corresponding to a specified pile load embedded in soil containing a cavity, is more than the load of pile embedded in soil without cavity. This behavior is due to the reduction in passive zone developed in front of the pile. One can notice from Table (3) that the existence of a cavity near the pile tip has no effect on working load. At pile tip, the passive zone is developed on the back face of the pile.

Fig. (5) shows the variation of working load versus cavity depth. Generally, increasing the depth of cavity, increases the working load.

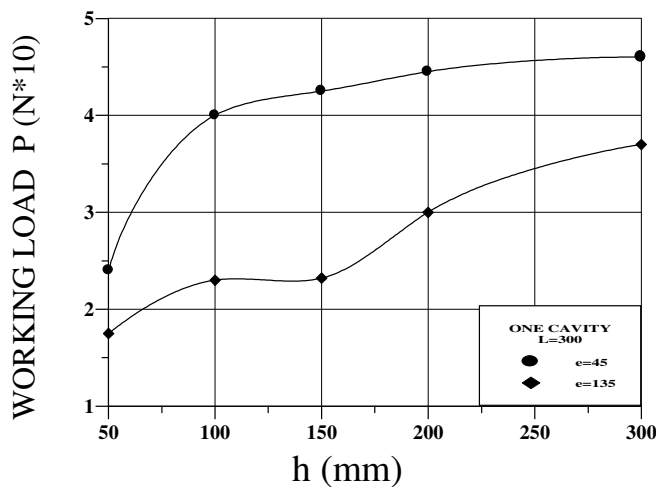

**Fig.(5):** Variation of working load versus cavity depth with varying load eccentricity. (group II, one cavity, L=300mm)

Fig. (5) indicates that at a certain depth of cavity, an increase in eccentricity decreases the working load.

Figure (6) shows the variation of  $P_c/P_o$  versus  $h/L$  where  $P_c$  indicates that the pile working load embedded in soil contains single cavity in front and in touch with pile face and  $P_o$  indicates the corresponding load of pile embedded in soil without cavity.



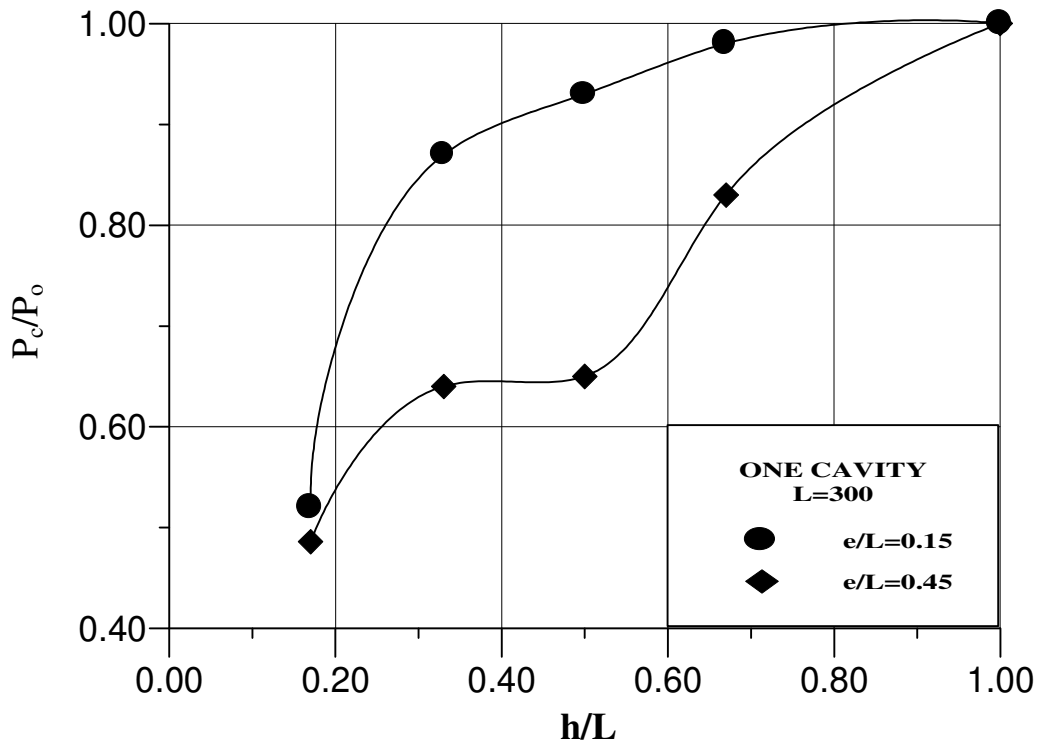

Fig.(6): Variation of  $P_c/P_o$  ratio with  $h/L$  ratio at different eccentricity ratios (group II, one cavity,  $L=300\text{mm}$ )

One can notice that the effect of cavity on the working load of pile is more pronounced as long as the cavity is near the ground surface. A reduction in pile working load is about 48 to 52% when the cavity is located at about one sixth of pile length with  $e/L = 0.15$  and  $0.45$  respectively, see Fig. (5). This behavior may be due to the fact that with increasing  $h/L$  the cavity gradually goes outside of the passive zone. Thus the effect of cavity near the tip of pile is negligible.

**Group III: The cavity is in touch and at back face of the pile**

Fig. (7) shows the variation of load versus horizontal displacement at variable depth of cavity. The working load for each pile is given in Table (4).

Table (4): Working load of pile embedded in soil containing one cavity at the back of the pile face.

h (mm)	0	100	200	300
$P_c$ (N)	46	46	45.5	40

\* $h=0$  denotes soil without cavity

Fig. (8) shows the variation of  $P_c/P_o$  versus  $h/L$ . It is clear that the cavity has no effect on the working load of pile as long as it is located in the active zone. The active zone is located approximately in the upper two-third of pile length.

The working load of pile is reduced to about 13% when the cavity is located near the pile tip.

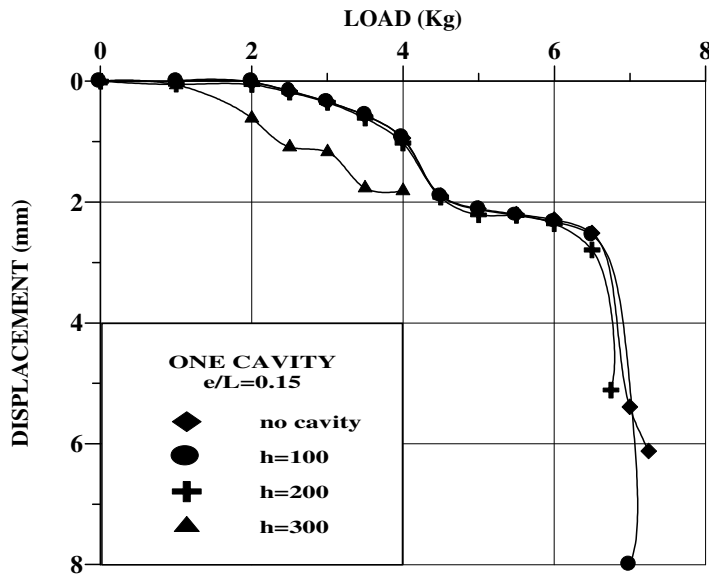

Fig.(7): Variation of load versus displacement with varying cavity depths from soil surface (group III, one cavity,  $e/L=0.15$ )

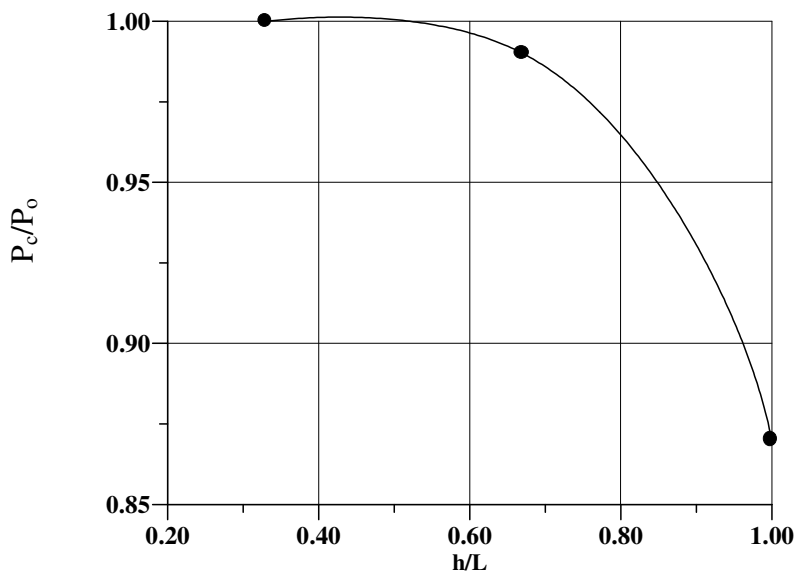
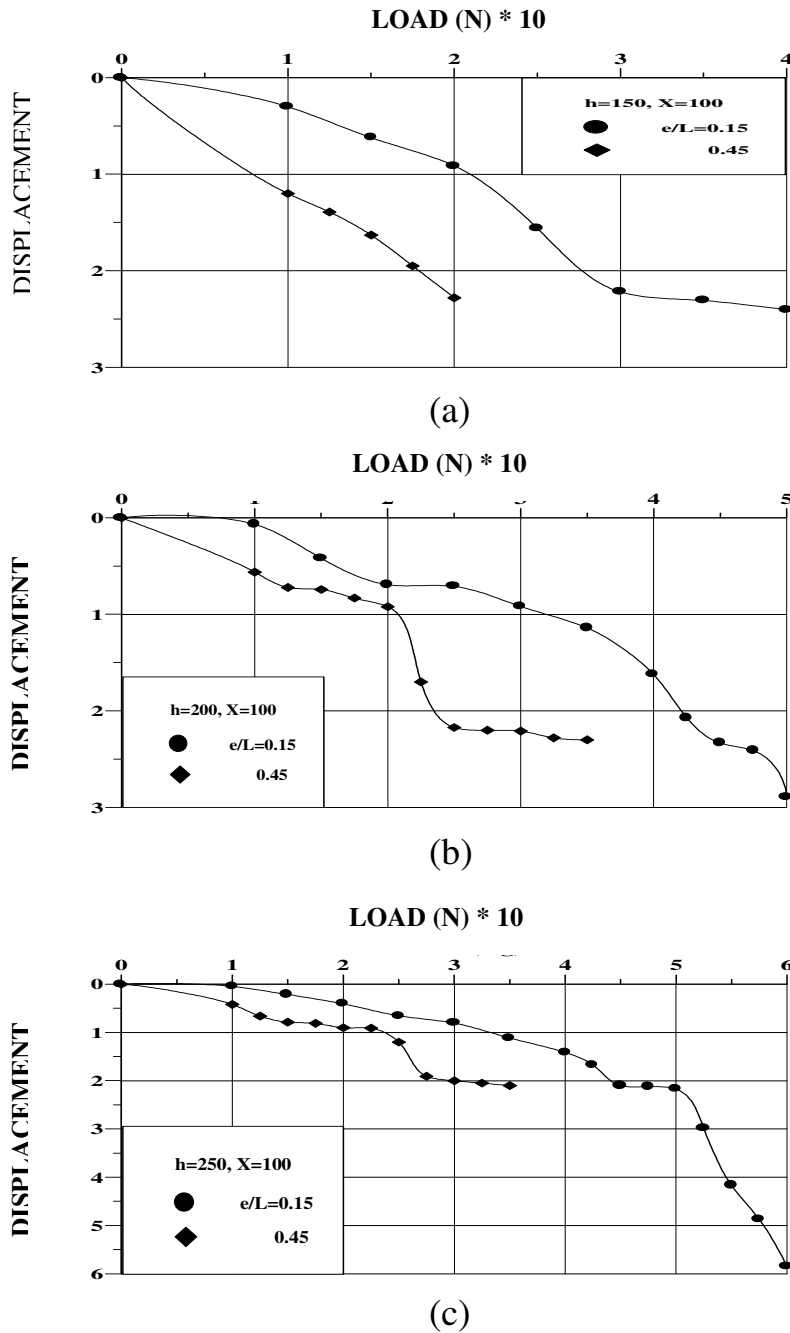

Fig.(8): Variation of  $P_c/P_o$  ratio to  $h/L$  ratio for cavity at back face of the pile (group III, one cavity,  $e/L=0.15$ )

**Group IV: Piles embedded in soil containing two cavities**

The location of the cavities are shown in Table (1). The cavities are located in front and in touch with pile face. Fig. (9) shows the relationship between the lateral load and the horizontal displacement with varying  $e/L$  ratio.



**Fig.(9):** Variation of load versus displacement with varying  $e/L$  ratio (group IV, two cavities,  $L=\text{constant}=300\text{mm}$ ,  $X=100\text{mm}$ ). (a)  $h=150\text{mm}$  (b)  $h=200\text{mm}$ . (c)  $h=250\text{mm}$ .

The load required to produce 2 mm horizontal displacement (i.e working load) is given in Table (5). It should be mentioned that  $X=0$  and  $h=0$  denote the working load embedded in soil without cavity.

Table (5): Working load for laterally loaded pile embedded in soil containing two cavities in (N)

h mm	X mm	L = 300 mm		Remarks
		e = 45(mm)	e = 135(mm)	
		e/L		
		0.15	0.45	
0	0	46	36	
150	100	27.1	17.6	
200	100	42	24	
250	100	44.3	30	
150	150	28	20	
200	150	41.3	23.5	
250	150	43.5	26.8	

\*h=0 denotes soil without cavity

Fig.(10) shows the variation of working load versus depth of the center of the two cavities. It is clear that the location of the cavities near the ground surface has a pronounced effect of the performance of laterally loaded pile. Generally, the location of the cavities near the pile tip have a negligible effect on working load.

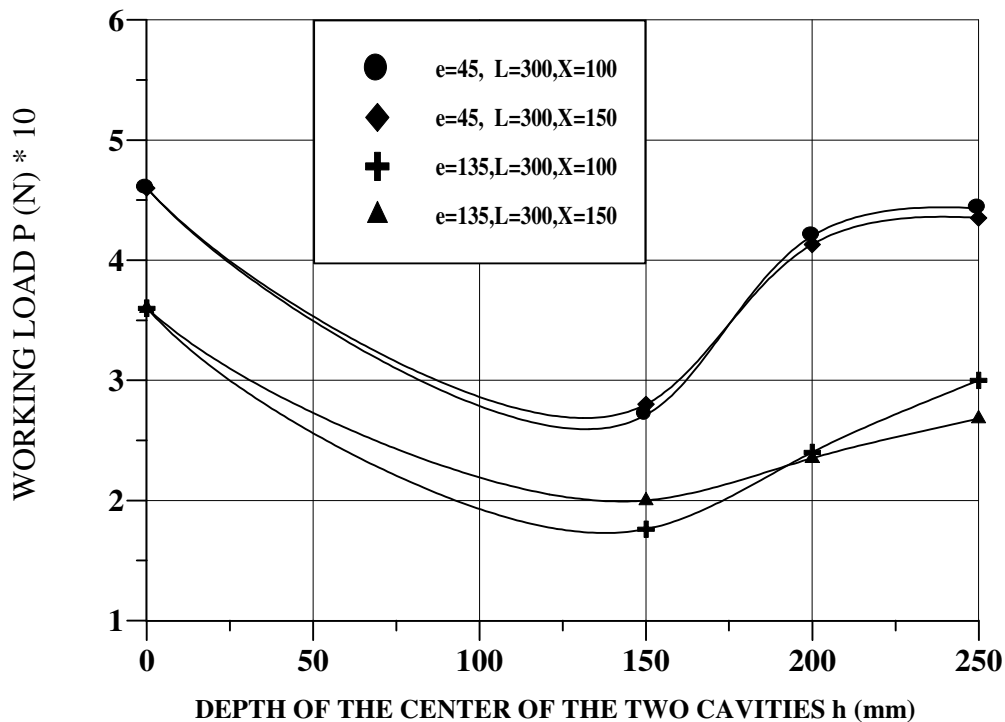

Fig.(10): Variation of working load versus depth of the center of the two cavities, h.  
 Note: h=0 indicates soil without cavity.

The increase in eccentricity causes decrease in the pile load capacity provided that the increase in eccentricity causes decrease in the pile load capacity provided that (L) is constant.

The spacing between the two cavities (X=100 mm and 150 mm) has a smaller effect on the performance of the pile than other parameters.

The curves tend to be asymptote as long as the location of the cavities approaches the tip of the pile.

Figs.(11) and (12) show the relationship between  $P_c/P_o$  with  $h/X$  for two cases of X=100mm and 150mm, respectively.

Obviously, the existence of cavities in front of the pile affects the performance of the pile under the lateral load. They reduce the pile capacity. The working load of pile with the existence of two cavities with X=100 mm and  $h=150$  mm and  $e/L=0.15$  reduces to about 40%. The reduction in pile capacity is due to reduction in passive zone, as long as the cavities exist in the passive zone (which is located at the upper two-third of pile embedded length) the more reduction in working load.

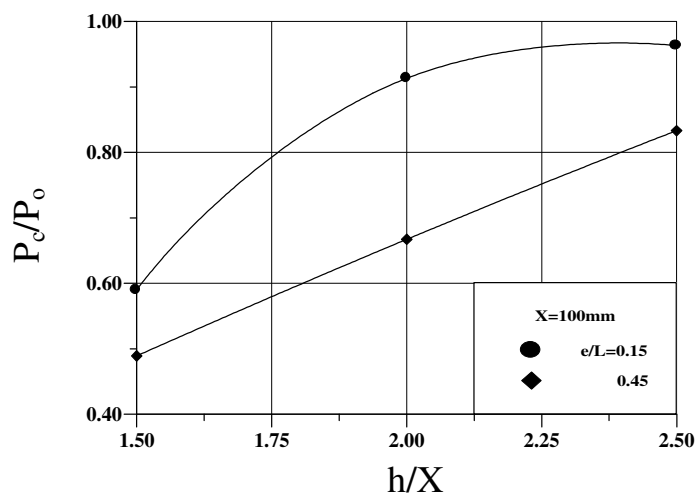

Fig.(11): Variation of  $P_c/P_o$  versus  $h/X$  with varying  $e/L$  ratio X=100mm

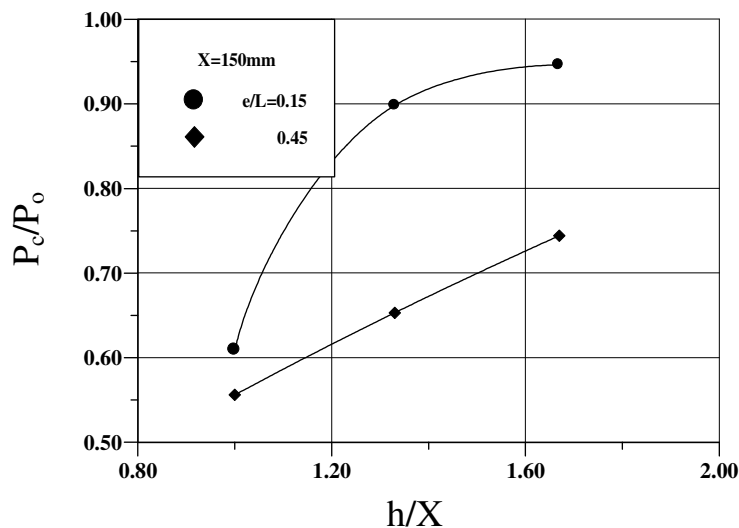

Fig.(12): Variation of  $P_c/P_o$  versus  $h/X$  with varying  $e/L$  ratio X=150mm

#### Group V: Piles embedded in soil containing three cavities

The arrangement and location of the cavities are shown in Table (1).

The tests are performed on a pile embedded in soil containing three cavities, and the cavities are located at  $X/D = 0, 2, 4, 6$  and  $8$  ( $D=15\text{mm}$ ).

Fig.(13) shows the variation of horizontal load versus horizontal displacement with eccentricity ratio  $e/L$  equal to  $0.15, 0.3, 0.45$  and  $0.60$

In general, increasing the lateral load causes an increase in the horizontal displacement. At a certain level of load, the horizontal displacement increases with the decreases in  $X/D$  ratio.

The loads required to produce  $2\text{ mm}$  horizontal displacement for each case are shown in Table

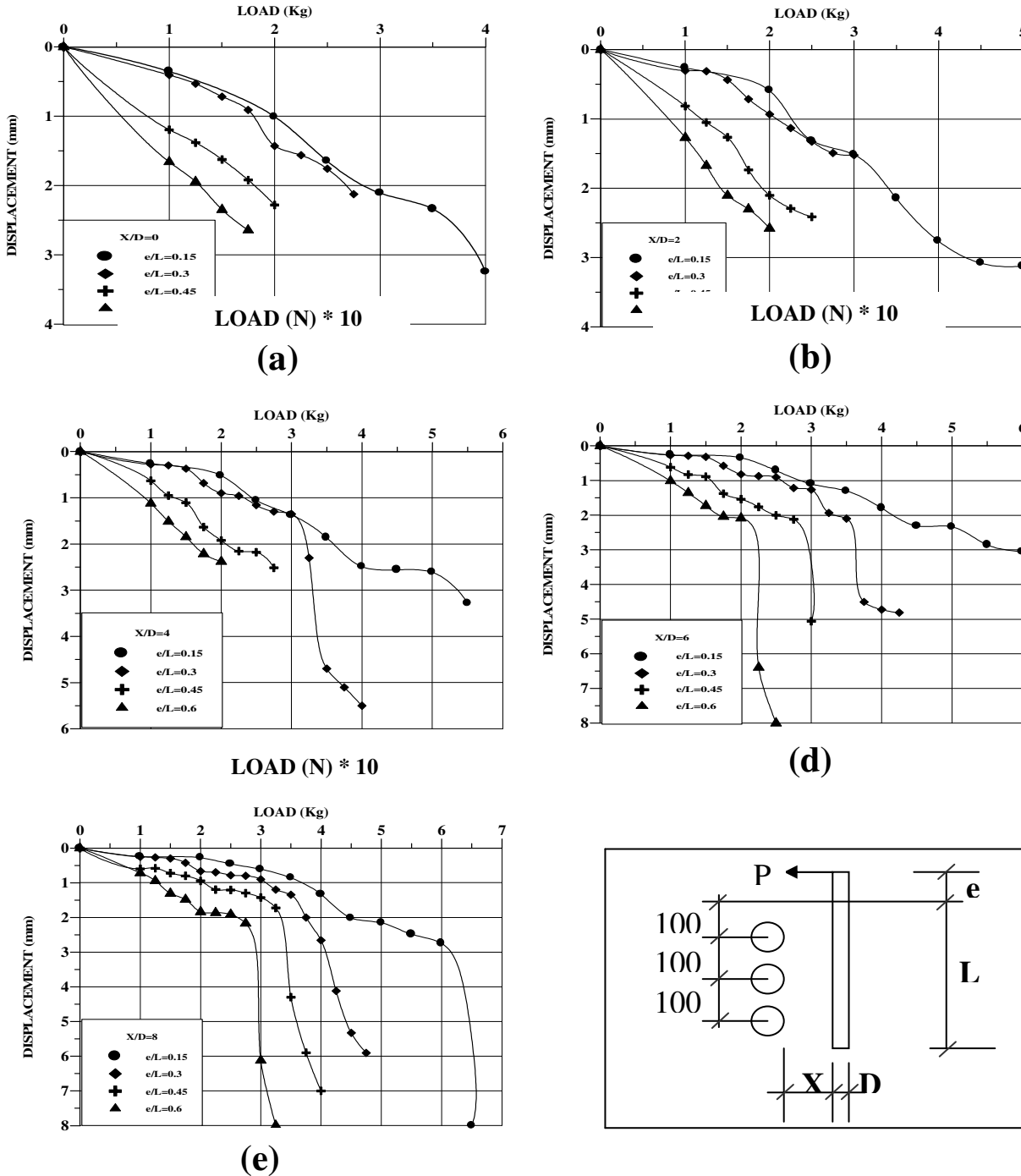

Fig. (13): Variation of load versus displacement with varying  $e/L$  ratio (group V, three cavities,  $L=\text{constant}=300\text{mm}$ ).  $X/D=(a) 0$  (b)  $2$  (c)  $4$  (d)  $6$  (e)  $8$

(6).

Table (6): Working load of piles embedded in soil contains three cavities, in (N).

X/D	L=300mm			
	e/L			
	0.15	0.30	0.45	0.60
0	27	26	17.5	12.5
2	34	30	18	14
4	35.5	32	21	16
6	41.5	32.5	25	17
8	45.5	37.5	34.5	27

It is obvious from Table (6) that the working load increases with the increase in X/D ratio for all values of eccentricity ratio. Fig. (14) shows the variation of the ratio of  $P_c/P_o$  ( $P_c$  = the working load of pile embedded in soil containing three cavities), ( $P_o$  = the working load of pile embedded in soil without cavity) versus X/D.

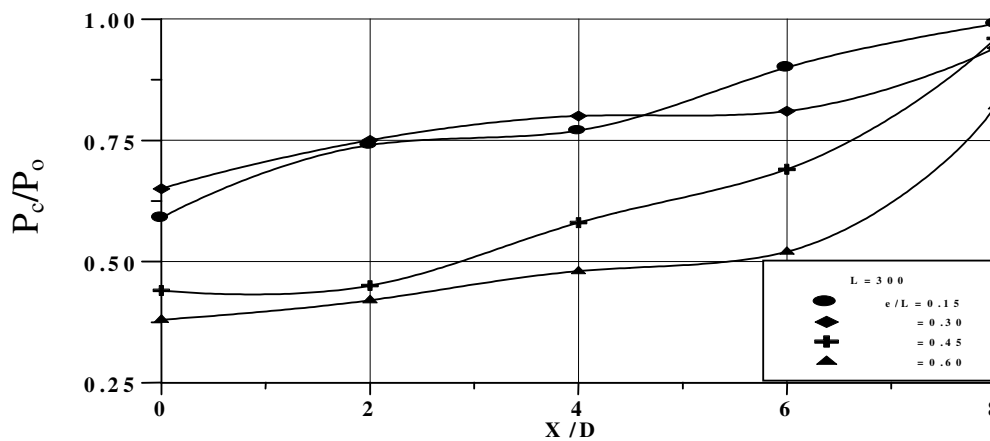
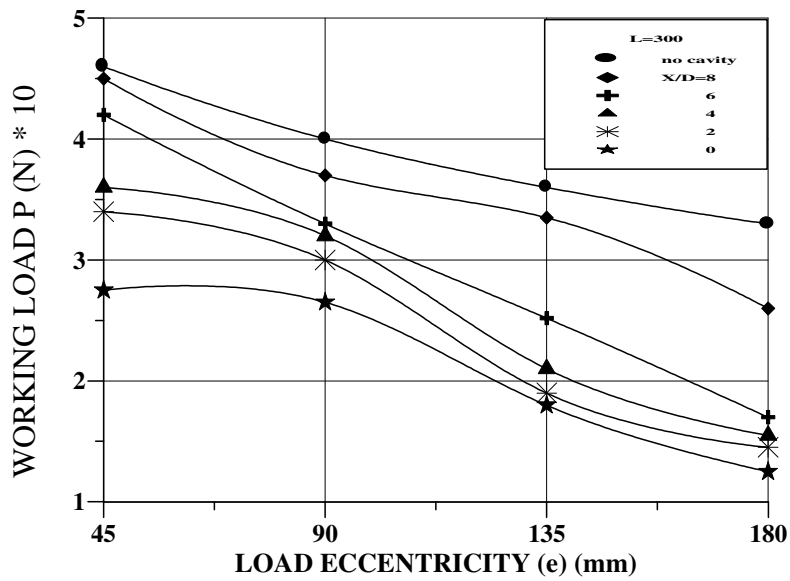

Fig. (14): Variation of  $P_c/P_o$  versus X/D ratio (group V, three cavities).

At a specified X/D ratio, the value of  $P_c/P_o$  decreases with the increase in eccentricity ratio. In general, it is clear that  $P_c/P_o$  increases with the increase in X/D and approaches to one at X/D = 8, i.e. the working load of piles embedded in soil containing three cavities approaches the working load of pile embedded in soil without cavity.

Fig. (15) shows the variation of working load versus load eccentricity and X/D ratio. It is clear that with the increasing in X/D ratio, the working load increases, and at a specified X/D ratio the working load increases with the decrease in eccentricity.



(a)

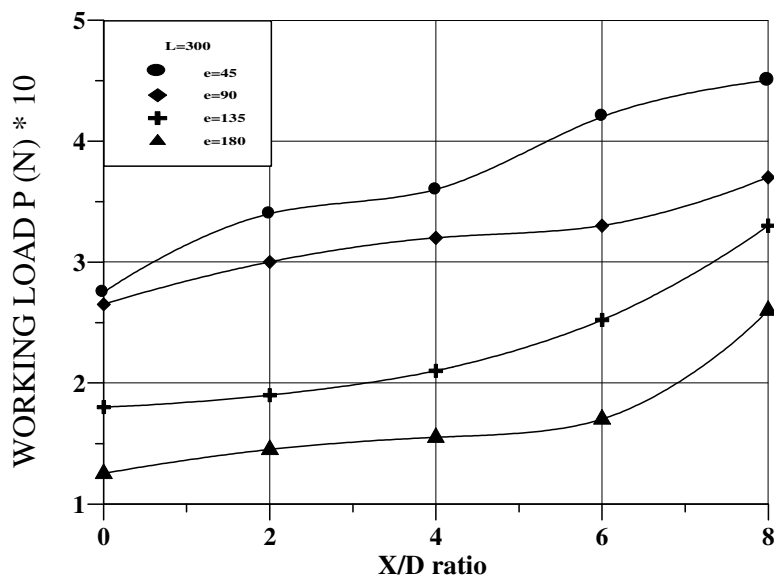

(b)

Fig. (15): Variation of working load versus (a) load eccentricity (b) X/D ratio (group V, three cavities, L=constant=300mm).

## CONCLUSIONS

Conclusions of a general nature are warranted only by extensive and conclusive tests under a wide variety of conditions. The following conclusions, therefore, are confined to the soil condition, pile type and cavity arrangement under which the tests are made:

- 1- There is a combined effect of the number of cavities and their location on the performance of laterally loaded pile. The existence of cavities in the passive zone of soil causes reduction in pile capacity.





- 2- The reduction in pile capacity increases as long as the existence of cavities is in front of pile and closer to the pile face and near to the ground surface. The reduction decreases as the cavity goes deeper and approaches zero near pile tip.
- 3- A reduction in pile working load is about 48% and 52% when the cavity is located at about sixth of pile length from the surface of the soil with eccentricity ratio 0.15 and 0.45 respectively.
- 4- The cavity located at the back of pile and in touch with pile face has no effect on the performance of the pile as long as it is located in the upper two third of the pile embedment length. The working load is reduced to about 13% when the cavity is located near the pile tip.
- 5- The effect of cavities located in front of pile is marginal at  $X/D > 8$ , where X is the spacing between cavity and pile and D is the diameter of pile.
- 6- In general, the existence of a number of cavities in soil in front of a pile affects the performance of laterally loaded pile. With the increase in the number of cavities (i.e. more reduction in passive zone) the pile capacity decreases.

## REFERENCES

- Al-Shakarchi, Y. J., 1965; "Combined action of pile and soil under the effect of the lateral load", Al-Muhandis, Journal of the Iraqi Society of Engineers. serial 31 Dec. 1965 No. 3, year 9<sup>th</sup>, p.p. 29-41.
- Al-Taie S. M., 2004; "Performance of laterally loaded pile embedded in sandy soil with cavities" M.Sc. thesis, University of Baghdad, College of Engineering, Civil Dept., Iraq.
- Badie, A. and Wang, M.C., 1984; "Stability of spread footing above void in clay", Journal of the Geotechnical Engineering Division, ASCE, Vol.110, No.11, p.p. 1591-1605.
- Bowles J.E., 1988 "Foundation analysis and design", 4<sup>th</sup> edition, McGraw-Hill, New York.
- Broms, B. B., 1965; "Design of laterally loaded piles ", Proc. ASCE., Vol. 91, SM3, part 1, p.p. 79-99
- Hopkins, D. A., 1956 Discussion to paper by McNulty J.S.M.F.D., ASCE Vol. 82 No. SM4, paper 940.
- Kashat, I.K., 1990 "Effect of load inclination on the behavior of pile" M.Sc. thesis, College of Engineering, University of Baghdad.
- McNulty, J. F. 1956 "Thrust loading on Piles" J.S.M.F.D., ASCE Vol. 82 No. SM2, paper 940.
- Soneja, M. R. and Garg K. G., 1980; "Under-ream piles under lateral loads", Indian Geotechnical Journal. Vol.10, No.3, p.p. 232-244.
- Ziyazov, Ya. Sh., 1976; "Performance characteristics of horizontally loaded piles located near a trench", Soil Mechanics and Foundation Engineering, ASCE. Vol. 13, No.3, p.p. 165-167.

## NOTATION

- $C_u$  = coefficient of uniformity.  
 $D$  = pile diameter in (mm)  
 $D_{50}$  = mean grain size in (mm).  
 $D_r$  = relative density.

- $e$  = load eccentricity in (mm) or void ratio.  
 $e_{\max}$  = maximum void ratio.  
 $e_{\min}$  = minimum void ratio.  
 $e/L$  = eccentricity ratio.  
 $E_p$  = elastic modulus of pile material in (MPa).  
 $F_y$  = yield strength of the pile metal in (MPa).  
 $G_s$  = specific gravity.  
 $h$  = depth of cavity  
 $L$  = embedded pile length in (mm).  
 $P$  = lateral load in (N).  
 $P_c$  = the pile working load embedded in soil contains cavities in (N).  
 $P_o$  = the pile working load embedded in soil without cavities in (N).  
 $X$  = distance between two cavities in case of two cavities, or  
distance between pile and cavities in case of three cavities in (mm).  
 $\emptyset$  = angle of internal friction.